

Fissaggio

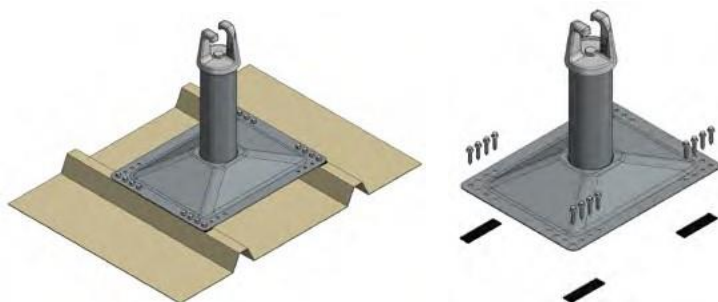

- Fissaggio con 16 viti autoperforanti dotate di rondelle stagne
- La tenuta stagna viene assicurata da rondelle stagne e da strisce adesive EPDM

Dimensioni

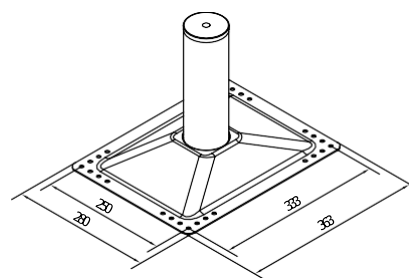

Palo di assorbimento

Accessori



Opzione

